

This document describes the setup procedure for the ISL8013EVAL1 Rev A board.

Description

The General Purpose market requires maximum flexibility in its power management solutions due to the large variety of applications produced each year. The ISL8013 services this need by offering a multitude of functionality, combined with features that allow it to work in many different application spaces.

From a functional standpoint, the ISL8013 is an ideal controller for designers that want a “plug and play” solution. It delivers a regulated output voltage from 0.8V to 5.5V at a maximum current of 3A, with 11 or fewer total components. Its 14 Ld HTSSOP package, combined with integrated MOSFET switches and compensation, yield a solution size below 0.36in². This small form factor makes the ISL8013 a desirable solution for any application where board space is a premium (PDAs, cell phones, etc.).

Additional features include a power good (PG) indicator for output voltage monitoring, and a clock frequency synchronizing input (SYNC). The SYNC input allows the regulator to switch anywhere between the nominal 1.4MHz frequency and 12MHz. Synchronizing multiple switching devices on the same bus eliminates beat-frequency oscillations that can be detrimental to noise-sensitive applications.

The ISL8013 supports power up into applications with pre-biased loads by allowing Pulse Frequency Modulation (PFM) during the soft-start period.

Overall, the ISL8013 delivers a robust, highly integrated DC/DC buck converter for a variety of General Purpose applications. For a more detailed description of the ISL8013, refer to the data sheet [1].

The Intersil General Purpose family of monolithic switching power supplies continues to expand with new selections to better fit our customer’s needs.

References

- [1] Refer to our website for updated information and the ISL8013 data sheet: www.intersil.com.

Features

- Less than 0.36in² footprint for the complete 3A converter
- Components on one side of PCB
- Max height 1.2mm HTSSOP14
- Power-Good (PG) output
- Internally-compensated voltage mode controller
- Up to 95% efficiency
- <1μA shut-down current
- Hiccup mode overcurrent and over-temperature protection
- External synchronization up to 12MHz
- Pb-free plus anneal available (RoHS compliant)

Ordering Information

PART NUMBER (Note)	TAPE & REEL	PACKAGE (Pb-Free)	PKG. DWG. #
ISL8013IVEZ	-	14 Ld HTSSOP	MDP0048
ISL8013IVEZ-T7	7"	14 Ld HTSSOP	MDP0048
ISL8013IVEZ-T13	13"	14 Ld HTSSOP	MDP0048

NOTE: Intersil Pb-free plus anneal products employ special Pb-free material sets; molding compounds/die attach materials and 100% matte tin plate termination finish, which are RoHS compliant and compatible with both SnPb and Pb-free soldering operations. Intersil Pb-free products are MSL classified at Pb-free peak reflow temperatures that meet or exceed the Pb-free requirements of IPC/JEDEC J STD-020.

Pinout

**ISL8013IVEZ
(14 LD HTSSOP)
TOP VIEW**

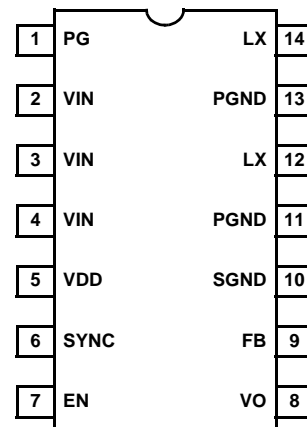

What's Inside

The Evaluation Board Kit contains the following materials:

- The ISL8013EVAL1 Rev A Evaluation Board
- The ISL8013 data sheet
- The ISL8013 Evaluation Board Setup Procedure (this document)

What is Needed

The following materials will be needed to perform testing:

- 1 electronic load [see note]
- 1 power supply: 0-6V @ 5A (see note)
- 2 precision digital multimeters
- Oscilloscope

NOTE: amperage rating of power supplies and loads are determined by maximum expected loading plus a percentage margin of error

Quick Setup Guide

- Step 1:** Set the +VIN power supply to +3.3V and place in the "STANDBY" or "OFF" position. Set the supply current limit to 5A. Connect the positive terminal (+) of the supply to the VIN terminal P4 and the negative terminal (-) of the supply to GND P5.
- Step 2:** Connect the positive terminal (+) of a DMM to the VIN terminal P4 and the negative terminal (-) to the GND terminal P5.
- Step 3:** Connect the positive terminal (+) of the electronic load to the VOUT terminal P7. Connect the negative terminal (-) of the electronic load to the GND terminal P8. Make sure the electronic load is set to the 0A condition.
- Step 4:** Connect the positive terminal (+) of a DMM to the VOUT terminal P7 and the negative terminal (-) to the GND terminal P8.
- Step 5:** Check to ensure all jumpers and switches are in their default positions prior to application of power (refer to Table 1).
- Step 6:** Set all power supplies to the "ON" position. LED D1 should be off. Check all DMM displays for correct voltage levels. Adjust if necessary.
- Step 7:** Turn the ENABLE switch S1 to the "ON" position. LED D1 should glow red. The VOUT DMM should read 1.80V ($\pm 5\%$).

At this point the board has been properly powered up. Normal testing can begin.

NOTE: If you need technical assistance, or other assistance, with the ISL8013 Evaluation Board, call 1-888-INTERSIL (468-3774).

TABLE 1. DETAILED DESCRIPTION OF SWITCH SETTINGS

SWITCH	POSITION	FUNCTION
S1	ON	ENABLE ISL8013
	OFF (default)	DISABLE ISL8013

TABLE 2. DETAILED DESCRIPTION OF TEST POINTS

REF DES	TYPE	FUNCTION
P1	Test Point	SYNC Input: HIGH = Force PWM LOW = Auto PFM/PWM Switching = Clock Sync
P2	Test Point	GND
P3	Test Point	PGOOD Output
P6	Test Point	External Enable NOT. S1 is required to be in the ON position.
J1	Oscilloscope	Kelvin LX Measurement
J2	Oscilloscope	Kelvin VOUT Measurement
P4	Binding Post	GND
P5	Binding Post	VIN
P7	Binding Post	VOUT
P8	Binding Post	GND

EVAL Board Information

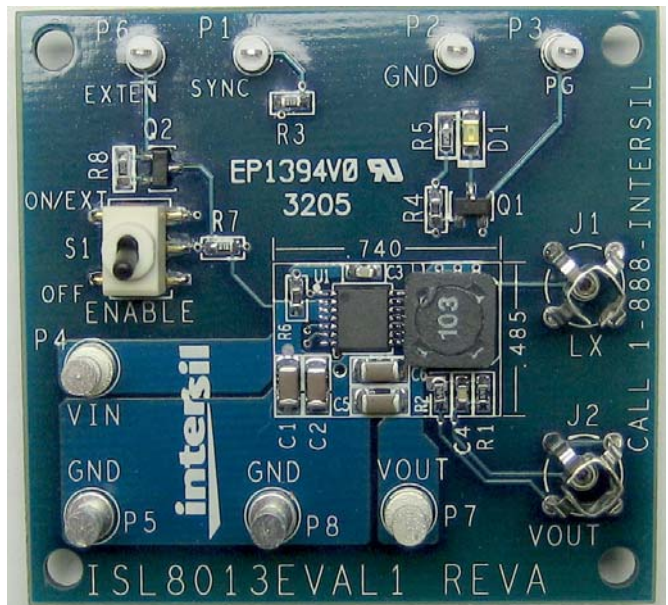
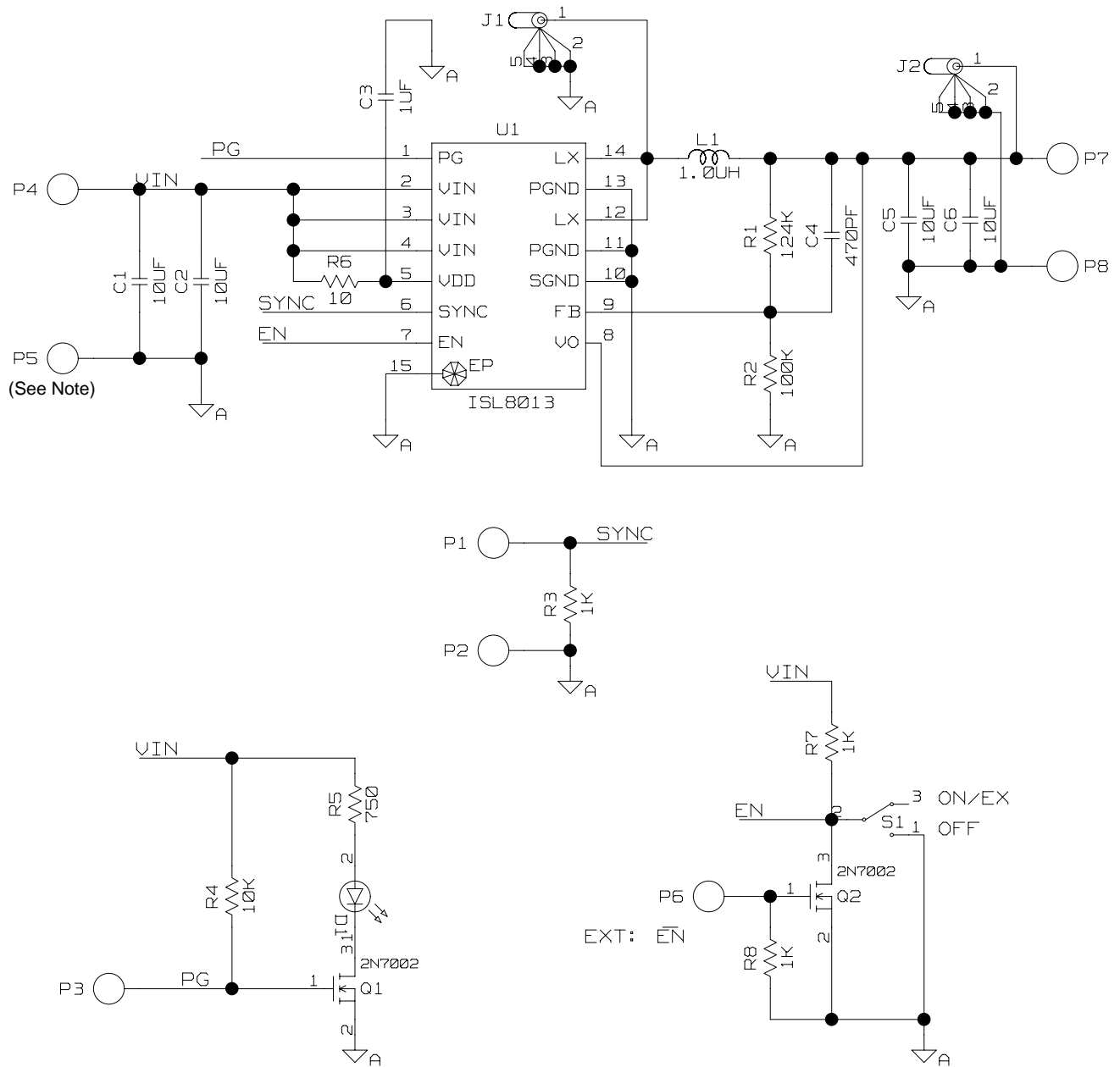

FIGURE 1. ISL8013EVAL1 REV A EVALUATION BOARD

Eval Board Schematic



NOTE: It may be necessary to place a high value electrolytic capacitor between VIN terminals P4 and P5 to eliminate power supply lead impedance.

Application Note 1241

TABLE 3. BILL OF MATERIALS

ITEM	QTY	REFERENCE	VALUE	TYPE	FOOTPRINT	VOLTAGE
1	1	U1		Intersil ISL8013	HTSSOP14	
2	2	J1, J2		Tektronix Scope Jack		
3	2	Q1, Q2		N-Channel MOSFET: 2N7002	SOT-23	
4	4	C1, C2, C5, C6	10 μ F	Generic ceramic capacitor	1206	6.3V
5	1	C3	1 μ F	Generic ceramic capacitor	0603	6.3V
6	1	C4	470pF	Generic ceramic capacitor	0603	6.3V
7	1	L1	1 μ H	Pulse: P1166.162		
8	1	S1		SPDT Switch: GT11MSCKE		
9	1	R1	124k Ω	Generic thick film chip resistor	0603	
10	1	R2	100k Ω	Generic thick film chip resistor	0603	
11	3	R3, R7, R8	1k Ω	Generic thick film chip resistor	0603	
12	1	R4	10k Ω	Generic thick film chip resistor	0603	
13	1	R5	750 Ω	Generic thick film chip resistor	0603	
14	1	R6	10 Ω	Generic thick film chip resistor	0603	
15	1	D1		Liteon: LTST-C170CKT	0603	
16	4	P1, P2, P3, P6		Test Points		
17	4	P4, P5, P7, P8		Binding Posts		

Eval Board Layout

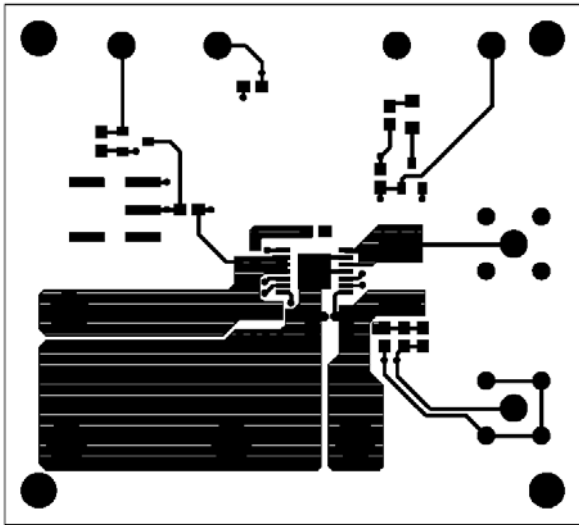

FIGURE 2. EVAL BOARD TOP LAYER ROUTING (ETCH)

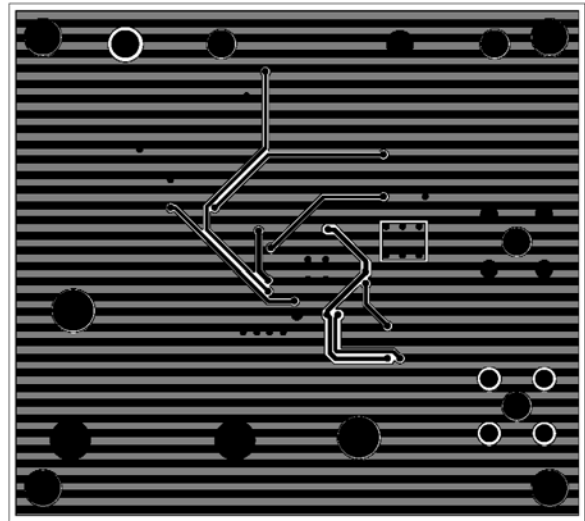

FIGURE 3. EVAL BOARD BOTTOM LAYER ROUTING (ETCH)

All Intersil U.S. products are manufactured, assembled and tested utilizing ISO9000 quality systems.

Intersil Corporation's quality certifications can be viewed at www.intersil.com/design/quality

Intersil products are sold by description only. Intersil Corporation reserves the right to make changes in circuit design, software and/or specifications at any time without notice. Accordingly, the reader is cautioned to verify that data sheets are current before placing orders. Information furnished by Intersil is believed to be accurate and reliable. However, no responsibility is assumed by Intersil or its subsidiaries for its use; nor for any infringements of patents or other rights of third parties which may result from its use. No license is granted by implication or otherwise under any patent or patent rights of Intersil or its subsidiaries.

For information regarding Intersil Corporation and its products, see www.intersil.com